

# PART No: SMY169036FW11

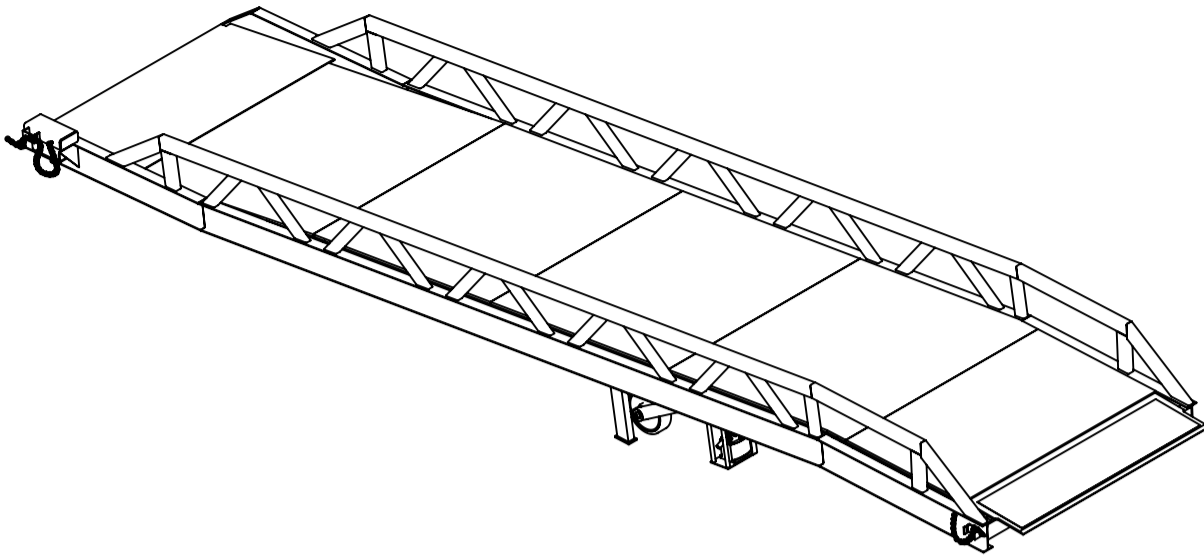

Seven tonne type 11 mobile yard ramp. A standard unit with an Intergrated entry ramp, high structural truss safety side rail, tow attachment, & manual hydraulic height adjustment for fast & efficient loading operations.

MATERIAL	Steel
WEIGHT	3,140 Kg
ESTIMATED LEADTIME	-
HEIGHT VARIATION	Min = 950mm Max Recommended= 1250mm Max = 1680mm
OPTIONAL EXTRAS	Chocks, Handrails

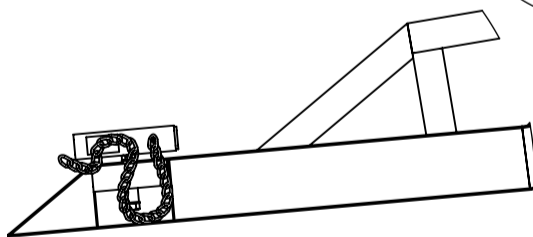
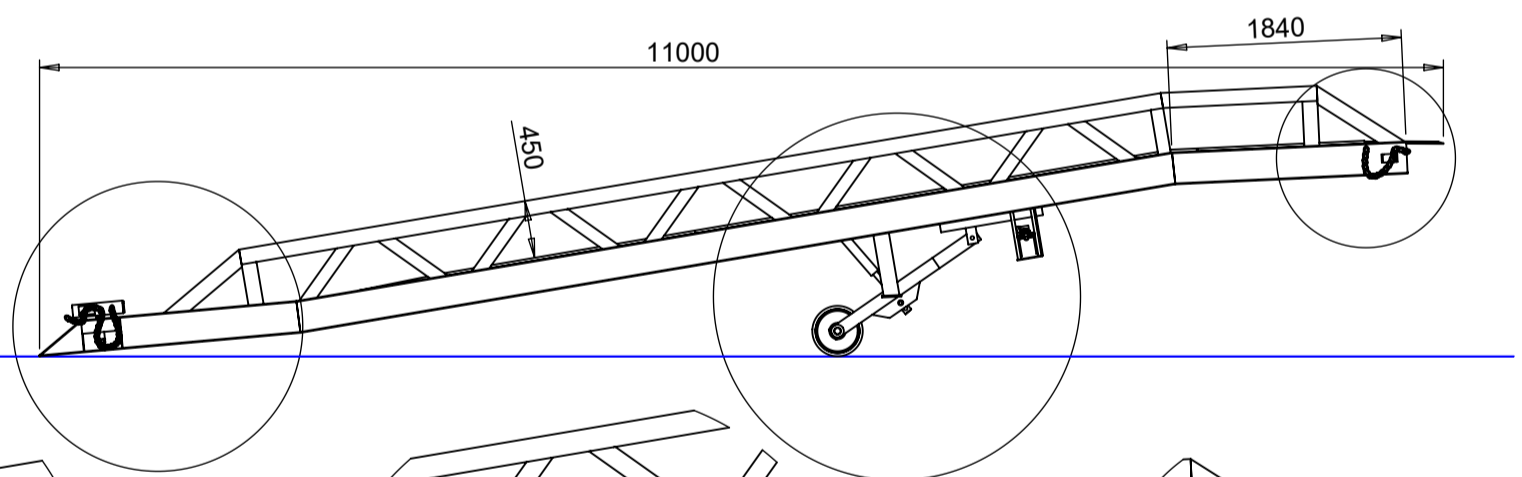
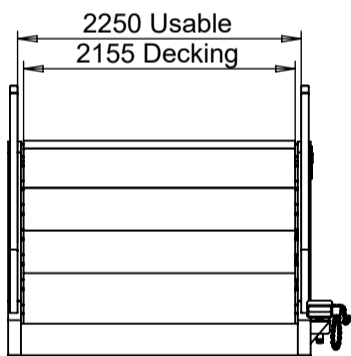
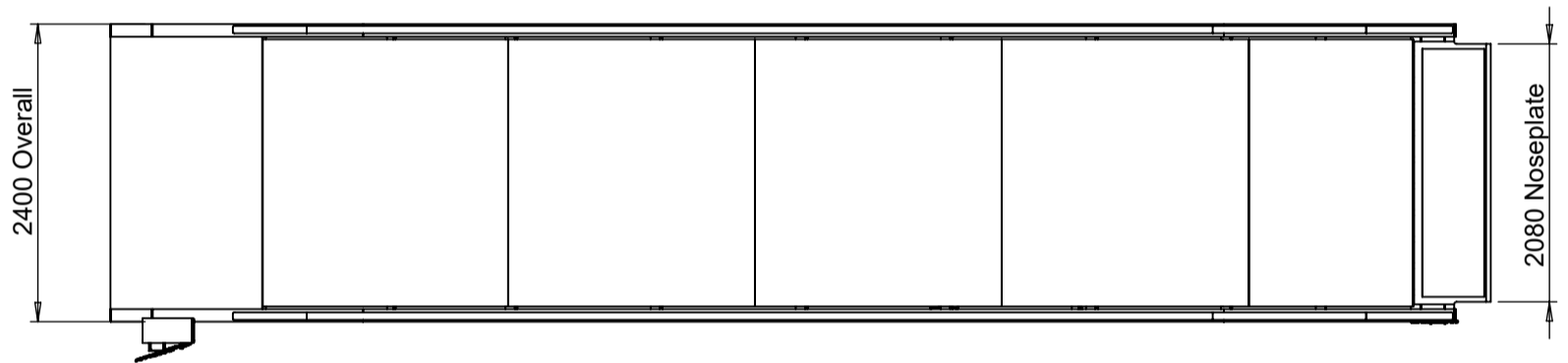

FIXED ENTRY RAMP AND TOWING ADAPTOR

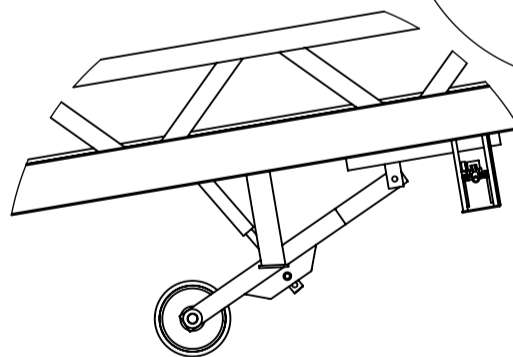

HYDRAULIC UNDERCARRIAGE FOR FAST & RELIABLE MANUAL HEIGHT ADJUSTMENT

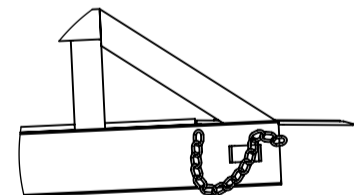

EXIT LIP AND CHAIN TENSIONING BRACKET FOR SAFE AND SECURE LOADING / UNLOADING

All dimensions shown are in millimetres and are intended for reference purposes only; exact product measurements may vary due to applied tolerances and methods of manufacture

The Intellectual Property, Design Patents, Copyright and Commercial Rights of this drawing remain the private property of Thorworld Industries Ltd and may not be copied, replicated or used by any Third Parties without prior written approval.

