

## USER MANUAL: MOBILE YARDRAMPS

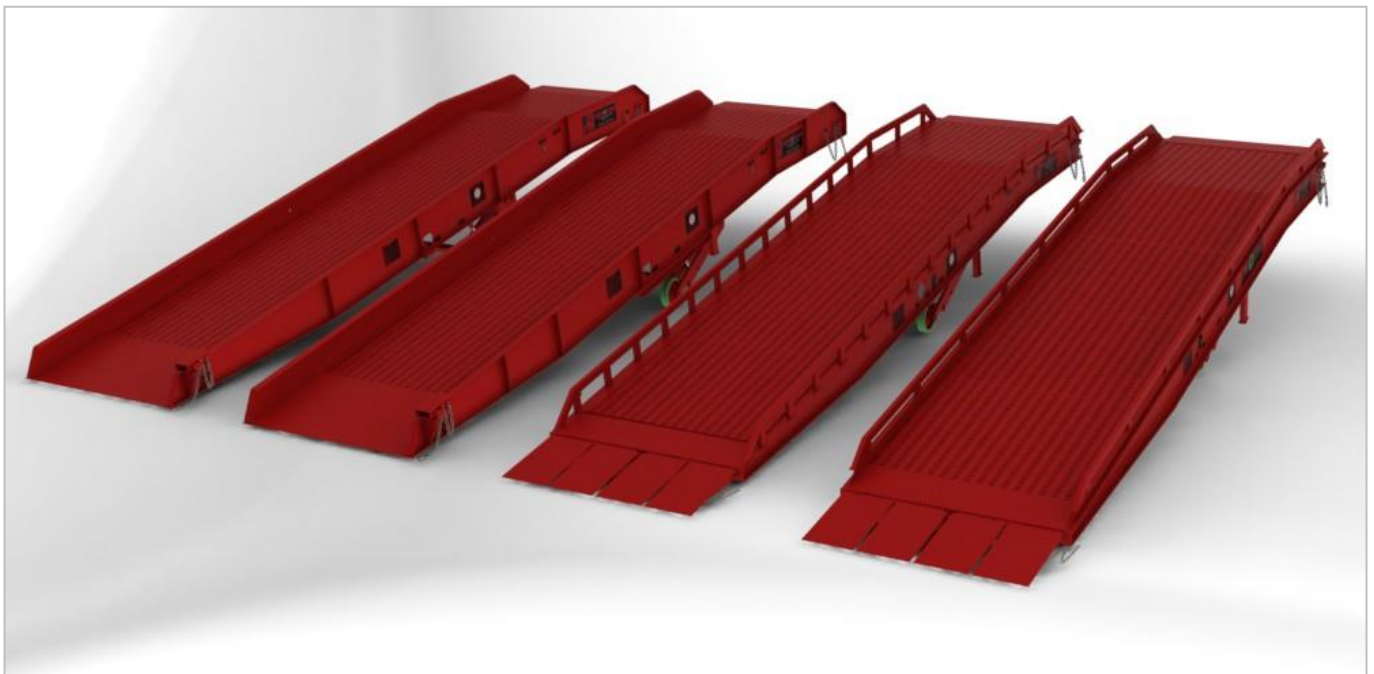

# Contents

<b>1.</b>	<b>Product Description.....</b>	<b>1</b>
1.1.	Identification and Entry Type.....	1
1.2.	Common Terminology .....	2
<b>2.</b>	<b>Transportation - Unloading .....</b>	<b>3</b>
2.1.	Low-Loaders.....	3
2.2.	Crane.....	3
2.3.	Double-Stacked delivery .....	4
<b>3.</b>	<b>Operation.....</b>	<b>5</b>
3.1.	Raising the Ramp.....	5
3.2.	Lowering the Ramp .....	5
3.3.	Towing / Positioning .....	5
3.4.	Setting Up For Use.....	6
3.5.	Loading / Unloading Operation.....	7
3.6.	After use .....	7
3.7.	Storage .....	7
3.8.	Other Guidelines.....	7
3.9.	Training.....	7
3.10.	Accessories .....	8
<b>4.</b>	<b>Maintenance .....</b>	<b>10</b>
4.1.	Pre-Use Checks by Operators .....	10
4.2.	Checks by Competent Maintenance Personnel.....	10
4.3.	Electrical Checks by Competent Electrician.....	11
4.4.	Replacement Parts, Accessories, Oil & Grease.....	12
<b>5.</b>	<b>Risk Assessment .....</b>	<b>13</b>
5.1.	Operation.....	13
5.2.	Maintenance .....	14
<b>6.</b>	<b>Legislation.....</b>	<b>15</b>
<b>7.</b>	<b>Warranty .....</b>	<b>15</b>
7.1.	Terms of Warranty.....	15
7.2.	Site Location Notification Form .....	15
<b>8.</b>	<b>Updates .....</b>	<b>15</b>

# 1. Product Description

Yardramps must only be operated by trained operatives and maintained only by competent engineers. The operatives must be aware of all the operating procedures.

## 1.1. Identification and Entry Type

There are two distinct yardramp designs, both with a range of optional features that their entry type differentiates. There are 'folding entry' and 'integrated entry' type ramps and there are subtle differences in the operating instructions between the two.

### **Folding Entry (Types 5, 6, 8 and 10)**

Yardramps with folding entry have a set of flaps that hinge down to give a constant entry gradient. These act as a barrier to entry when the ramp is out of use. There is also a built in push-pull type tow bar which hitches to the back of a FLT with an external towing pocket.



### **Integrated Entry (Types 7, 9 and 11)**

Yardramps with integrated entry have an entry plate that comes right down to the floor, and as such the entry angle is variable, depending on the height at which the ramp is being used. As such, the entry gradient is always equal to the main ramp gradient. As a result, these types of ramp can be shorter, and in some cases have a harsher entry for the forklift truck. There is also a built in push-pull type tow attachment into which one of the FLT forks enters and is then secured with a chain.



## 1.2. Common Terminology

The schematic below shows typical location, and terminology of parts used on a Yardramp:

### Folding Entry Type

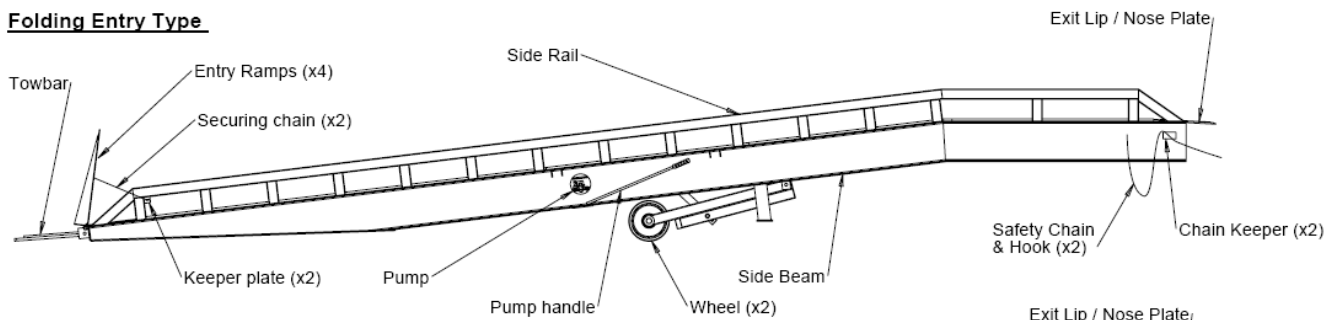

### Integrated Entry Type

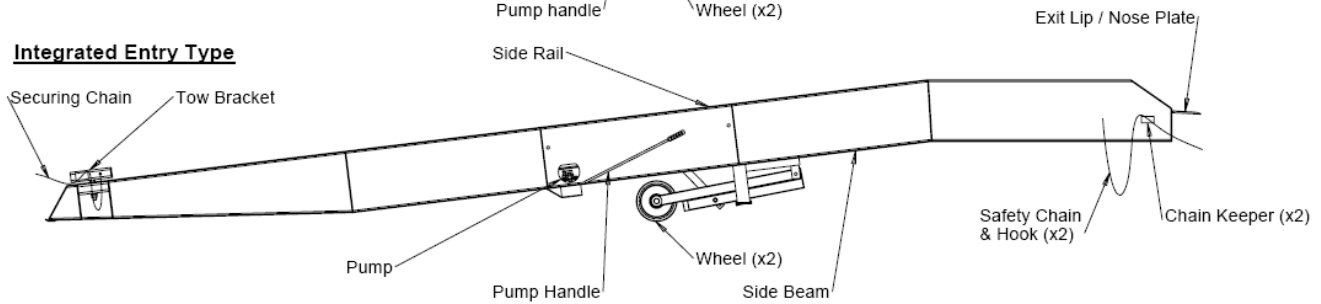

### Pump Detail

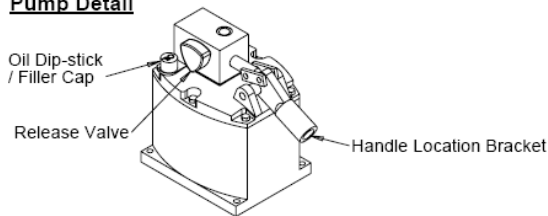

### **General:**

FLT – Fork Lift Truck

### **Ramp Specific:**

Entry End – the lower end of the ramp which sits on the ground.

Exit End – the upper end of the ramp, which positions in the vehicle.

Entry Ramps/Plate – the sloped section of ramp at the Entry End.

Nose Plate / Exit Lip – Anti-slip plate which sits in the back of the vehicle to be loaded / unloaded.

## 2. Transportation - Unloading

Unload generally as described below – it is the responsibility of the user to ensure that a full and thorough Risk Assessment is carried out prior to commencing the operation.

### 2.1. Low-Loaders

Thorworld recommends the use of a low loader type vehicle for delivery of its Yardramps. The ramp is pulled off the trailer by forklift truck, using on its integrated wheels. The ramp does not need to be lifted off the trailer.



- (i) Position the low-loader on flat ground prepared for unloading. Ensure sufficient clear area to receive the ramp.
- (i) The HGV driver will act as the appointed person / lead throughout the process and will guide/instruct the fork truck operator accordingly.
- (ii) Raise ramp on its jacking wheel system (see Section 3.1 Raising the Ramp)
- (iii) Attach to FLT (see Section 3.3 Towing / Positioning). Unless agreed otherwise in writing prior to delivery, you are responsible for the offloading, including the supply of a forklift truck, and competent operator. The forklift truck must be a minimum 2,000Kg capacity, 4-wheeled design (i.e. without a central rear wheel or pair of wheels) with towing pocket/pin.
- (iv) Pull ramp off into the clear area and manoeuvre into required position.
- (v) To load the ramp, reverse the above process.

### 2.2. Crane

Lifting holes are situated on the upper flanges of the side beams. These are positioned about the ramps centre of gravity, and so all 4 must be used to ensure a safe lift.

28mm Diameter Holes for 24mm Diameter lifting eye bolts (not provided).  
*N.B. Holes are not included with the 15,000Kg capacity ramps (Boat Slings are recommended)*

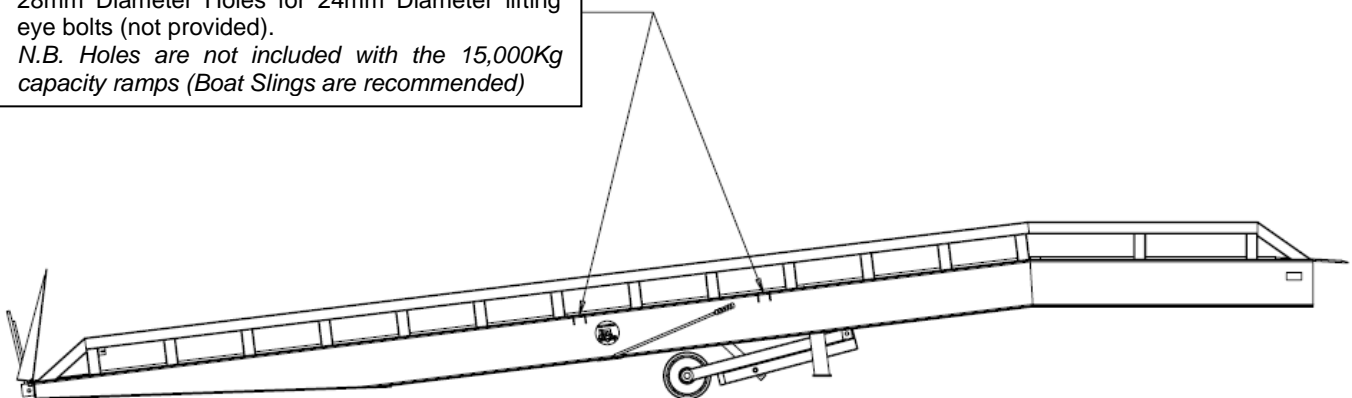

### 2.3. Double-Stacked delivery

Separate instructions will be provided.



## 3. Operation

### 3.1. Raising the Ramp

All Thorworld yardramps are raised and lowered by means of a hydraulic hand pump. The main features of the pumps are the release valve to the left hand side of the pump and the handle location bracket to the front (as detailed right). To raise the ramp:

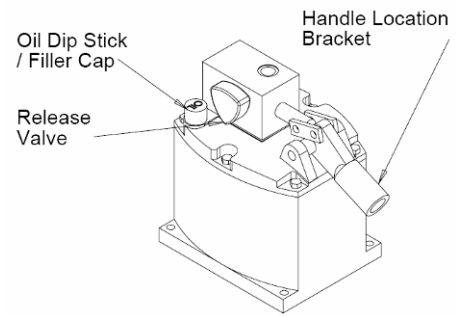

- Ensure the release valve on the pump is fully tightened (clockwise).
- Remove the handle from its storage location in the side beam of the ramp and insert it fully into the handle location bracket. Pump in a smooth motion, taking care not to apply excessive force at the end of each stroke (top and bottom).
- Once the desired height is achieved, remove the handle and place it back in its holder on the side beam. The handle must not be left in the pump unattended.
- **Additional notes for ramps fitted with electric pumps:**

With power connected, press and hold the switch to raise the ramp, after first closing the release valve as above.

Release the switch once the desired height is achieved.

To prevent damage to the motor, do not run the pump when its maximum height has been reached.

When the ramp tops-out, oil will return to the tank via the internal relief valve. This will be audible and when this happens the button should be released.

See 0

*Electric Powerpack:* for further details.

### 3.2. Lowering the Ramp

This is done by slowly opening the release valve on the left of the pump, by turning anti-clockwise – the rate of descent is controlled by varying the amount the valve is opened.

### 3.3. Towing / Positioning

Pump the unloaded ramp to a sufficient height to prevent the legs catching on the floor whilst moving, then connect to the FLT by following the instructions below specific to your ramp type.

#### 3.3.1. Ramps with folding entry ramps:

The tow bar is located at the entry end of the ramp, under the hinged entry ramps and is designed for use with FLT's that have an external towing pocket; if there is only an internal towing pocket on the FLT, an adaptor must be used (contact Thorworld for details).

- **Entry Ramps:** Ensure the entry ramps are secured in the vertical position before moving the ramp:
  - The inner ramps must be raised first – they are retained by the outer ramps.
  - When the outer ramps are in the vertical position they must be secured using the securing chains. The chains must be pulled taught through the side rails, locating one link in the keeper plate.
- **Connecting to FLT:** Raise the lower end of the yardramp with FLT forks positioned under the hinge tube and insert a solid block to support the ramp whilst the towbar is connected to the FLT towing point. The block remains in position whilst the ramp is moved away from it.
- Once the Yardramp is in position, remove the pin from the FLT and drive away, letting the ramp lower to the floor under its own weight.



#### 3.3.2. Ramps with integrated entry ramp:

This tow adaptor is found at the entry end of the ramp affixed to one of the side beams. It is free to rotate on its vertical axis, and incorporates a chain and keeper device for securing the ramp to the FLT.

- Insert one fork of the FLT into the pocket until it hits the backstop.
- Attach the chain to a suitably strong location on the FLT before removing all slack with the tensioning device.
- Raise the entry end of the ramp, and move around as necessary using the FLT.

- To release, reverse the above process.

### 3.4. Setting Up For Use

#### 3.4.1. **Positioning for Operation**

Below is a list of the general points to be considered when positioning your Yardramp for use; however it is the users responsibility to undertake a thorough assessment of the risks specific to the site where the Yardramp is to be used (it is advised that a written record of this assessment is kept):

- Ensure there is adequate clearance around the immediate vicinity of the ramp. Especially at the entry and exit ends, as well as the pump access area.
- Ensure there are no obstructions around the entry end, as well as over or under the ramp where its motion / movement may present hazards.
- Excessive floor gradients may present rolling problems, and may affect the height range specified for the model in question.
- Check for the presence of uneven ground, especially at the entry end. The ramp must not be used if the entry end of the ramp is not firmly sat on level ground.
- The ramps are designed to allow a small amount of torsional flexibility, but excessive differences in levels of the vehicle bed and ramp exit lip must be avoided.
- If entry ramps are present, these should remain in the upright position until after the Yardramp is securely fastened to the docking vehicle.

#### 3.4.2. **Raise the ramp:**

In order to position the ramp on the vehicle, follow the method described in section 3.1 *Raising the Ramp*; raising the ramp to a height of at least 50mm above the vehicle bed.

#### 3.4.3. **Setting the ramp onto the vehicle**

- Manoeuvre the vehicle back against the ramp, or the ramp up to the vehicle, ensuring the exit lip is fully inserted into the vehicle at both sides; if this is not possible for any reason you must inform Thorworld immediately as this can reduce the lifespan of the lip, and have safety implications.
- The ramp must now be lowered to meet the bed of the vehicle as described in section 3.2 *Lowering the Ramp*. Once the full weight of the ramp is resting on the vehicle, ensure the release valve is fully opened to allow the ramp to move up and down with the vehicle as it is loaded / unloaded.
- Thorworld strongly recommend that wheel chocks are used on the vehicle.

#### 3.4.4. **Securing the ramp to the vehicle**

- The ramp must now be secured to the vehicle using the two chains at the exit end of the ramp, in order to prevent the ramp and vehicle from separating during use. These must be secured to a suitably strong anchorage on the vehicle. The chains must be within a recommended range of +/-30° from horizontal; beyond this their effectiveness in preventing separation is greatly reduced. Contact Thorworld if you have any queries regarding the suitability of your chaining points.

The chains must then be passed through the chain keeper, lodging one chain link into the groove (leaving two links loose to prevent the chains locking as the ramp / vehicle move).

**IMPORTANT** - Ensure the chains are fitted correctly through the keeper / tensioning device, as shown in the images below, i.e. over the groove, down through the middle of the tensioning device and then out to the vehicle.



- As a further safety feature, Thorworld recommend the use of wheel chocks on the ramp.



### 3.5. Loading / Unloading Operation

The ramp is now ready for loading / unloading operations to commence:

- If the Yardramp has entry ramps, these must be lowered to the floor by removing the chains from the keeper plates, and lowering the external ramps first, followed by the internal ramps.
- The speed limit on the ramp is strictly 8km/hr (5mph), or as designated on the signage clearly seen on the side of the ramp.
- There must only ever be one forklift truck on the ramp at any one time.
- Never ascend the ramp using a forklift / load combination that exceeds the rated load capacity of the ramp. This rating is clearly designated on the ramp signage.
- Always enter/exit the ramp straight in order to prevent damage by forks/load to the side rails or entry ramps.
- **Never force/push items whilst on the ramp. (i.e. the last row of goods in a tightly packed container).**

### 3.6. After use

- After completing the loading / unloading operation, reverse procedure *3.4 Setting Up For Use*.
- In order to reduce any hazards resulting from loose chains, when not in use they must be stored in the position pictured in section *3.4.4 Securing the ramp to the vehicle*.
- The ramp must be washed and/or brushed clean after use if the deck has become excessively dirty or blocked with debris.
- You must also raise and secure the entry ramps (if present), and secure the ramp wheels with wheel chocks.

### 3.7. Storage

The ramps can be stored in a pumped up position, or fully lowered to the ground; though storing in the raised position can be a safety hazard should anyone be able to gain unauthorised access to the ramp; for example if the yard is left unsecured overnight.

If the ramp is to be out of use for an extended period, it is recommended that it be stored in the lowered position.

### 3.8. Other Guidelines

Ramps must only be operated in accordance with the instructions outlined in this manual and must only be operated by users deemed competent to do so.

General safety hazards to reiterate and be aware of:

- NEVER ascend the ramp whilst the hydraulic release valve is in the closed position. This will lock the cylinder(s), preventing the ramp from safely moving up and down with the vehicle.
- No pedestrians on the ramp unless handrails are fitted (as well as adequate anti-slip surfaces, particularly if the ramp is to be used outdoors). If pedestrians are to use the ramp, they must never be permitted onto the ramp at the same time as a forklift truck.
- The Total Load (FLT weight plus its load) must not exceed the rated capacity.
- Only one FLT must be on the ramp at any one time.
- Thorworld Yardramps are designed, tested and approved using four wheeled trucks. If three wheeled trucks are used, the load on the flooring is increased significantly and as a result additional flooring supports will be required.
- Thorworld do not recommend loading / unloading an articulated trailer where no tractor unit is present due to the risk of tipping. If you must operate like this, Thorworld suggest that the 5<sup>th</sup> wheel be supported with our Trailer Safety Support. Caution must be taken when loading / unloading the first / last loads respectively due to the risk of the trailer tipping with the weight of the Yardramp and FLT. If possible, the back of the trailer must also be supported with a Trailer Safety Support at a suitably strong point or by other means.
- Do not use salt/grit to clear ice or snow as it will cause corrosion. If the ramp has Bimagrip Antislip, light brushing only is recommended.

### 3.9. Training

Thorworld recommend that all operatives of its yardramps undergo training to operate the ramps, after which certificates are awarded to competent operatives. Please enquire for further details and prices.

### 3.10. Accessories

Accessories / Extras that may be fitted to the ramp on request.

#### 3.10.1. One-Man Operation (Telescopic) Tow Adaptor:

This adaptor can be fitted to Folding Entry Type ramps, allowing the ramp to be moved in a similar way to Integrated Entry Type ramps, for one-man operation.

- Ensure the standard towbar (located at the bottom, centre of the ramp) is removed:
  - Pull out the tow pin retaining R-clip, followed by the tow pin itself, and lastly the tow bar. Retain for future use.
- Ensure the entry ramps are raised and secured in the vertical position, see section 3.3.1 *Ramps with folding entry ramps*.
- Ensure the telescopic arm is extended and locked into position before moving the ramp:
  - Remove locating pin.
  - Pull the towing pocket to extend the telescopic arm.
  - Secure the locating pin to prevent the arm from retracting.

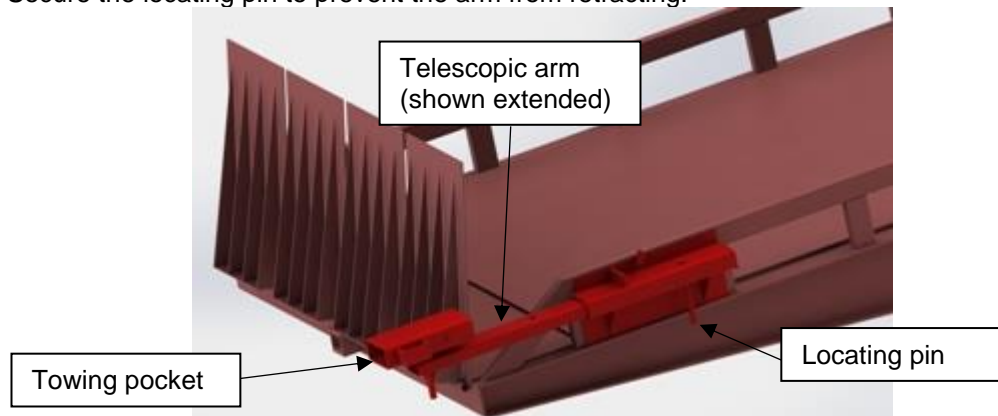

- The ramp can now be moved in accordance with 3.3.2 *Ramps with integrated entry ramp*.
- Retract the telescopic arm when the ramp is in position to prevent impact, by reversing the above, i.e:
  - Remove locating pin.
  - Push the towing pocket to retract the telescopic arm.
  - Secure the locating pin to prevent the arm from extending.

### 3.10.2. Fork Truck Towing Adaptor:

This adaptor can be used with ramps with Folding Entry Type ramps. The stand-alone adaptor attaches to standard fork truck tines/stanchions, and allows you to move the ramp in a similar way to Integrated Entry Type ramps, for one-man operation.

- Ensure the standard towbar (located at the bottom, centre of the ramp) is in place.
- Ensure the entry ramps are raised and secured in the vertical position, see section 3.3.1 *Ramps with folding entry ramps*.
- Position forks on your FLT to align with the pockets of the towing adaptor and secure in place (in accordance with your fork truck operating instructions).
- Drive the fork truck, pushing the forks into the adaptor until they reach the end of the pocket.
- Attach the chain to a suitably strong location on the FLT before removing all slack with the tensioning device.
- Remove the towing pin out of the adaptor to allow clear access when connecting the ramp tow bar.
- Use the fork truck to position the towing adaptor up to the ramp tow bar.
- Make minor adjustments to the towbar / adaptor alignment by hand, and insert the towing pin once aligned with the towbar hole. Secure the towing pin in place using the locking bolt.
- The ramp can now be moved in accordance with 3.3.2 Ramps with integrated entry ramp:.
- To release, reverse the above process.

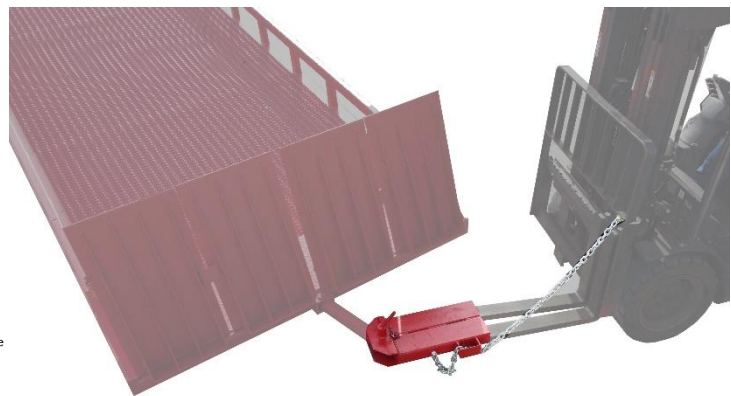
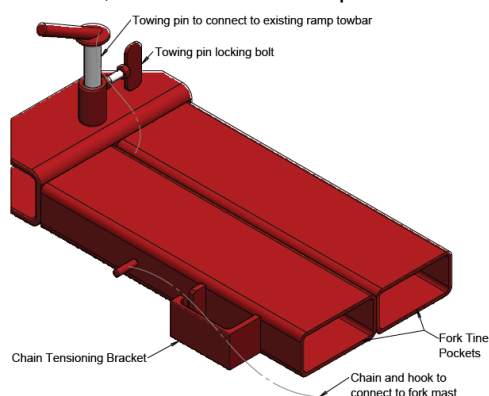

### 3.10.3. Electric Powerpack:

An alternative to the standard hydraulic hand pump is the option of an electrical pump, this can be used to raise the ramp with the press of a button. The electrical pump is available in three types, 110V, 240V, and 415V depending on the power available on site.

#### Power supply requirements:

- 1.5 KW Min
- RCD (30ma) required (for fitment by others).
- A steel wire armoured cable is required with trailing socket by others. This must be kept dry with the power off / isolated until it has been connected to the ramp. Plug provided on the ramp:

Voltage (depending on model fitted)	Plug provided
415v 3-phase	5 Pin / 32 Amp (neutral not used)
240v AC	3 Pin / 16 Amp
110v AC	3 Pin / 32 Amp

- If power supply does not meet these criteria, the ramp may not operate correctly.

#### Operation.

Operation follows section 3 *Operation*.

The ramp can either be raised using the manual pump, or electric powerpack (3.1 *Raising the Ramp*). Irrespective of the method used to raise the ramp, the ramp is lowered using the same method as described in 3.2 *Lowering the Ramp*.

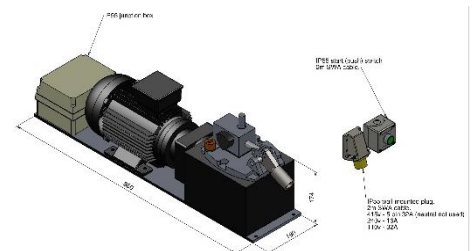

## 4. Maintenance

It is vital that your equipment is maintained in order to ensure continued safe operation, and achieve its maximum intended life span.

**IMPORTANT:** Maintenance checks must only be carried out by a 'competent person' after ensuring suitable and sufficient risk assessments have been carried out. If any work is to be done under the ramp, suitable measures must be taken to prevent a crushing hazard.

Thorworld can provide additional safety devices to reduce risk whilst carrying out maintenance operations – contact us for more information.

### 4.1. Pre-Use Checks by Operators

All operators using the equipment must undertake a basic pre-use check, looking out for potential hazards including:

- (i) Damage to / general condition of the flooring / deck
- (ii) Absence of any safety devices / retaining chains etc
- (iii) Ensure safety chains are located correctly through the tensioning device (see section 3.4.4 *Securing the ramp to the vehicle.*)
- (iv) Pools of oil or leaking hydraulics.
- (v) All pivot pins and retaining clips are present and serviceable, i.e. wheel pins, cylinder & undercarriage pivots, and pivot points on hydraulic handpump.
- (vi) Towing facility and safety signage is all in place
- (vii) Obvious dents or cracks in the side rails, entry ramps or exit lips

If any problems are noted – do not use the ramp until consulting your maintenance department, or contacting Thorworld.

### 4.2. Checks by Competent Maintenance Personnel

A schedule for maintaining the equipment must be adhered to by competent maintenance personnel; the following being a recommended guideline for this purpose, in addition to the pre-use checks above:

#### 4.2.1. **Weekly Checks**

- (i) Lubricate pump mechanism (and inspect for obvious damage)
- (ii) Ensure wheel chocks are stored with the ramp
- (iii) Check for loose nuts or bolts holding retaining chains.
- (iv) Check general cleanliness of ramp, specifically ensuring the decking is free of debris.

#### 4.2.2. **Monthly Checks**

- (i) Check hydraulic fluid level - reservoir to be at least  $\frac{3}{4}$  full when ramp is at minimum height
- (ii) Check for excessive damage to the tyres
- (iii) Grease wheel bearings and all pivot pins
- (iv) Check for presence of tow bar and retaining chains, and any damage
- (v) Check hydraulic system for damage or defect; including, but not limited to, leaks from cylinders, pump and hoses, tightness of fittings, and loosening of cylinder head/gland (see drawing in section **Error! Reference source not found.**).
- (vi) Ensure all signage is still clearly visible
- (vii) Check exit lip for signs of damage / cracking / bending
- (viii) Check undercarriage for any signs of damage
- (ix) Check the deck grating for any signs of damage (broken welds etc)
- (x) Check for damage to armoured cabling, contactor box, switch and plug. (if electric powerpack is fitted)

#### 4.2.3. **Annual Checks**

In order to fulfil your legal obligation under the European Use of Work Equipment Directive 89/655/EEC (PUWER regulations within the UK) Thorworld recommend a inspection/service be carried out on an annual basis by a 'competent person'. This inspection/service can be carried out by ourselves or other body (please enquire for details and pricing).

All Thorworld inspection/service visits are carried out in accordance with periodic inspection guidelines written by The FEM (European Federation of Materials Handling) Elevating Equipment Product Group.

Such checks must include, but not be limited to:

- (i) Thorough check of deck grating
- (ii) Check all over for any damaged welds
- (iii) Check main side beams / curbs and rails for any signs of damage
- (iv) Check entry ramps for signs of damage (where applicable)
- (v) Check all cross beams and sub-frame for any sign of damage
- (vi) Check operation of hydraulic system (including through check of individual components)
- (vii) Check that the ramp has not been modified from the original design

- (viii) Presence and functionality of fixings, i.e. nuts, bolts and clips.

With proper use and regular maintenance your Thorworld Mobile Yardramp will give many years of service.

This maintenance schedule is a general operational outline for competent personnel and applies to all Yardramp models. Thorworld Industries Ltd reserves the right to modify product designs, details and construction without notice.

#### **4.3. Electrical Checks by Competent Electrician**

If the ramp is fitted with an electrical powerpack accessory, the following additional checks are recommended by a competent electrician:

##### **4.3.1. 3-Monthly Checks**

- (i) RCD test

##### **4.3.2. Annual Checks**

- (ii) Portable Appliance Testing (PAT)

## 4.4. Replacement Parts, Accessories, Oil & Grease

### 4.4.1. Replaceable Parts

The following items are readily replaceable (in most cases on-site):

- Undercarriage Assembly and Wheels
- Hydraulics System (pump, cylinders, hoses & fittings)
- Hydraulic pump and cylinder seal kits
- Entry Ramps and Hinge Assembly
- Chains and Keepers
- Tow Assembly
- Legs
- Signage and Decals

The following items are replaceable, but are considered major works and so it is likely that the Yardramp would have to be returned to our works for repair or refurbishment:

- Floor / Decking
- Nose Plate
- Entry infill Plates
- Side Rails

The schematic below shows typical location, and terminology of parts used on a Yardramp:

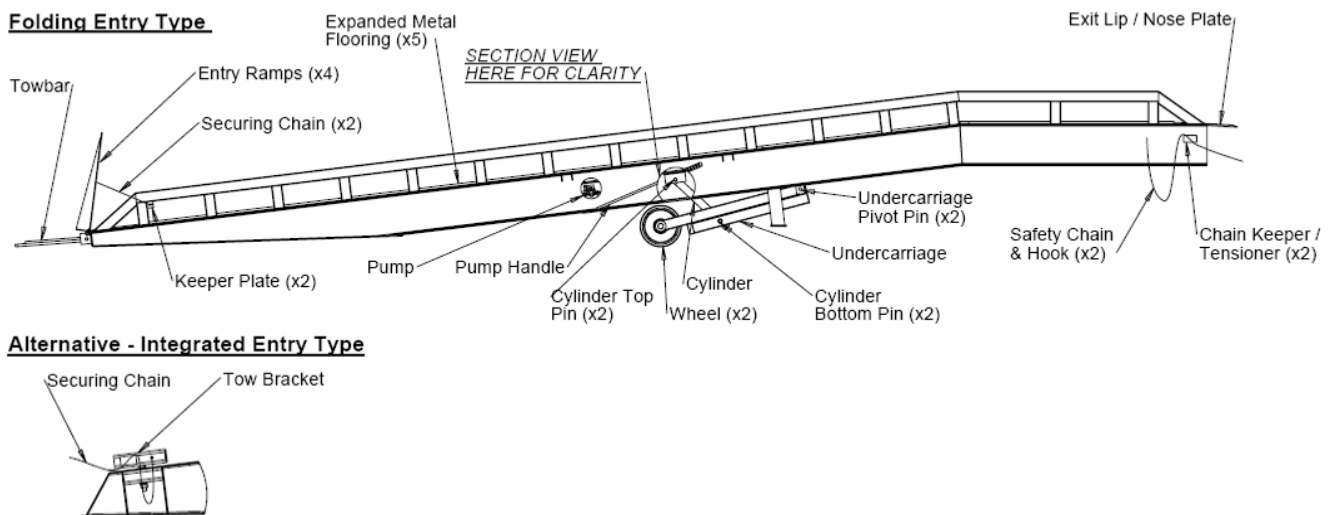

### 4.4.2. Non-Replaceable Parts

Parts in the main Yardramp structure are generally not replaceable, and damage to one of these parts would typically require that a new ramp be sought.

- Side Beams or Side Profiles
- Cross Members
- Longitudinal Members

### 4.4.3. Accessories

There are a number of accessories available for Yardramps, including:

- Push Type Towing Adaptor (for folding entry type ramps) – Use standard FLT forks to push the ramp in front, rather than towing from behind; can be retro fitted to any existing ramp.
- Electric Pump – To allow electrical control of the raising / lowering mechanism.
- Wheel Chocks – One set (4-off) to secure the ramp wheels when it is stationary, and another set (4-off) to be used on the docking vehicle, to hold it in place whilst loading operations are carried out.
- Trailer Safety Support – To support the load in a trailer when loading operations are undertaken on trailers where the cab unit is not present.
- Safety Signs – To increase visual communication of hazards and guidelines, increasing awareness of health and safety requirements beyond the recommended minimum.
- Handrails – Recommended where personnel operate on the ramp.

Contact Thorworld for more information on any of the above items.

### 4.4.4. Recommended oil & grease

- Hydraulic Oil: Grade/Type 32
- Grease: EP2 lithium grease.

## 5. Risk Assessment

As with all equipment and operations, it is vitally important that a full and thorough risk assessment is carried out prior to using and/or maintaining the ramp.

Thorworld cannot carry out the risk assessment for you as there will be many areas specific to your site which will need to be considered, we have however detailed below the main hazards associated with the use of the ramp. The list is by no means exhaustive, and the proposed solutions must be considered in relation to your operation – a solution that works for one company, may not be suitable for another (It is advised to keep a written record of any risk assessments).

### 5.1. Operation

The following hazards must be considered and assessed prior to using the ramp in a (un)loading operation.

#### **5.1.1. Connecting tow bar to FLT (Folding entry type only)**

On ramps with folding entry ramps, the towing bar is fitted to the rear towing point of a fork lift truck. This is a two person operation. Only approved and certified fork truck drivers must be used, and care must be taken when attaching the tow bar of the ramp to the towing point of the truck. Also consider risk of trapping. Appropriate PPE to be worn, for example gloves and safety footwear.

Telescopic towbar option available.

#### **5.1.2. Trapping of personnel between ramp and vehicle**

Whilst positioning ramp onto the vehicle (or vehicle back to the ramp) there is a risk of crushing any person who are stood between. Appropriate PPE to be worn, for example gloves and safety footwear.

#### **5.1.3. Trapping/crushing under the ramp**

No-one must go under the ramp at any time, other than a competent person to carry out relevant maintenance, as covered in section 5.2 Maintenance.

#### **5.1.4. Trapping/crushing under side beams and legs when lowering the ramp**

When lowering the ramp, it is important to ensure there no persons stands where the ramp rests on the ground due to the risk of trapping/crushing. This includes lowering the ramp on its hydraulics, and also when detaching it from the fork lift truck. Appropriate PPE to be worn, for example gloves and safety footwear.

#### **5.1.5. Risk of ramp disengaging from lorry / vehicle**

It is essential that the hooks and chains are in good condition and are correctly located to prevent the ramp from falling from a vehicle/container. Chains must be attached to a suitably secure point on the vehicle in accordance with section 3.4.4 Securing the ramp to the vehicle. It is important not to set the chains outside the recommended range of +/-30° from horizontal, as beyond this, their effectiveness in preventing separation is greatly reduced.

**Never force/push items whilst on the ramp. (i.e. the last row of goods in a tightly packed container).**

#### **5.1.6. Risk of vehicle prematurely pulling away from a ramp during use**

First and foremost, a safe system of work must be implemented, ensuring the correct use of the safety hooks/chains (see 3.4.4. Securing the ramp to the vehicle).

Secondary control measures should also be considered, including:

- Use of wheel chocks for both the vehicle and the ramp.
- Removal of drivers keys whilst (un)loading is in operation.
- Air hose locks which prevent the trailer from moving unless unlocked and released

#### **5.1.7. Crushing / trapping by entry ramps**

Ensure operatives are stood well back when lowering them to the ground. Appropriate PPE to be worn, for example gloves and safety footwear. Ensure they are raised / lowered in the correct sequence:

##### Lowering:

- Release chain from keeper plate in side rail
- Lower outer ramp
- Lower inner ramp
- Repeat on opposite side of ramp.

##### Raising:

- Raise inner ramp
- Raise outer ramp
- Secure chain into keeper plate in side rail, ensuring the chain loops around the outside of the side rail

### **5.1.8. Ramp tipping**

When not attached to vehicle: There must be no load applied to the ramp unless the nose plate is securely supported on a vehicle. The hydraulic system is not designed to support this load, and more importantly, the ramp could easily tip over if used in this way.

When connected to vehicle: Thorworld do not recommend (un)loading an articulated trailer where no tractor unit is present due to the risk of tipping. If it must operate like this, Thorworld suggest that the 5th wheel be suitably supported with our Trailer Safety Support, or an alternative support. Caution must be taken when loading / unloading the first / last loads respectively as the trailer can tip with the weight of the ramp and FLT in this situation. If possible, the back of the trailer must also be supported with a Trailer Safety Support at a suitably strong point or by other means.

### **5.1.9. Hand pump handle left protruding from the pump after use**

This can cause injury as it can leave a tripping hazard and/or a risk of impalement if walked into. Further to the risk of injury, impact from a passing vehicle can cause damage to the pump. It is important that the handle is put back into its storage point after pumping is complete.

### **5.1.10. Impact from pump handle during use**

It is important that the pump handle is fully inserted into the handle slot, and that pumping is smooth, to prevent the handle working loose during the pumping operation.

### **5.1.11. Risk of falling from ramp**

No pedestrians directly on the ramp unless handrails are fitted, (as well as adequate anti-slip surfaces, particularly if the ramp is to be used outdoors). Consider the whole (un)loading operation, and also any other need to walk up or stand on the ramp, e.g. to clear debris from the inside of the container, or inspect goods before unloading.

If pedestrians are to use the ramp, they must never be permitted onto the ramp at the same time as a forklift truck.

### **5.1.12. Risk of pedestrian impact with forklift / goods.**

Pedestrians must never be on the ramp at the same time as a forklift truck or any other vehicle. See above regarding use of handrails.

### **5.1.13. Impact from falling goods**

In certain circumstances, goods may fall from the FLT/ramp (reasons may include, but are not limited to poor packing of pallets/goods, incorrect ramp operation and/or incorrect FLT operation). Bystanders are at risk of impact from these falling goods; a safety zone around the ramp during operation must be implemented (size of zone to be determined by risk-assessment considering the details of your application). The addition of handrails to the side of the ramp may also help in this situation, depending on the nature of the goods.

### **5.1.14. Risk of ramp detaching from fork truck during movement**

Discuss fork truck / MHE suitability with your supplier. Keep the ramp uphill of the forklift when moving on a gradient.

### **5.1.15. Risk of loss of control whilst positioning/moving the ramp**

Discuss fork truck / MHE suitability with your supplier.

Plan the intended travel route – ensure it is smooth, stable, of appropriate construction material, and clear of obstruction.

Appropriate level of operator training.

### **5.1.16. Other points to consider**

- The Total Load (FLT weight + its load) must not exceed the rated capacity, and only one FLT must be on the ramp at any one time. Capacity signage must always be clearly displayed on the ramp
- It is important that the speed limit on the ramp is not exceeded, i.e. 8km/hr (5mph), or as designated on the signage clearly seen on the side of the ramp.

## **5.2. Maintenance**

The following hazards must be considered and assessed prior to carrying out any maintenance on the ramp.

### **5.2.1. Trapping/crushing under the ramp**

No-one must go under the ramp at any time other than a competent person to carry out relevant maintenance; when this is done, two forms of support must be used for safety, examples of which are detailed below:

- FLT of adequate capacity
- Supports / Jacks
- Crane with hooks and chains
- The undercarriage of the ramp if not damaged



### **5.2.2. High pressure hydraulic oil**

When supporting its own weight on the hydraulics, the hydraulic oil is under high pressure. It is important not to carry out any work on the hydraulics unless the pressure is released, i.e. the release valve is open, and ramp is supported as above.

### **5.2.3. General trapping, crushing, manual handling etc hazards associated with maintenance**

## **6. Legislation**

Thorworld Mobile Yardramps are UKCA and CE Marked, meeting the requirements of applicable UK and European legislation.

Thorworld Yardramps are designed from the outset with end-of-life / disposal considerations in mind, and therefore do not contain any substances listed in the Restriction of Hazardous Substances Directive (RoHS).

Further information on all of the above can be found on our website at:

- <http://www.thorworld.co.uk/regulations>

## **7. Warranty**

### **7.1. Terms of Warranty**

All new ramps manufactured by Thorworld carry a warranty for a period of 12 months. This warranty does not cover damage caused by impact or misuse and abuse.

### **7.2. Site Location Notification Form**

Our records monitor the location of every Mobile Yardramp produced by us, in order that we can maintain contact with our customers and carry out our obligation to notify you of essential health and safety requirements concerning your ramp. As such, if you move the ramp to a new site address we would appreciate being notified so that we can update our records accordingly.

Main contact: Liz Brown  
Address: Thorworld Industries Ltd  
Unit 37, Station Lane Industrial Estate  
Old Whittington  
Chesterfield  
Derbyshire  
S41 9QX  
E-Mail: [lizb@thorworld.co.uk](mailto:lizb@thorworld.co.uk)  
Telephone: +44 (0)1246 260981

## **8. Updates**

Contents of this User Manual may change due to changes in legislation or best working practices. Please see the individual product pages on our website for latest copies; [www.thorworld.co.uk](http://www.thorworld.co.uk).